

# carbatec



**2YR**  
WARRANTY

## OWNERS MANUAL

UNIVERSAL SLIDING EXTENSION TABLE

TS-C250P-UST

## 1. Introduction

Model TS-C250P-UST Universal Sliding Table Attachment easily installs on your Carbatec TS-C250P table saws to greatly increase crosscutting capabilities.

This addition to your table saw features a telescopic crosscutting fence with an adjustable flip stop for repeat cuts, and an industrial-grade sliding table with a linear guide mechanism for extremely accurate cuts.

Using the extension fence, you can crosscut workpieces up to 1500mm, the conveniently positioned fence can also be rotated 60° left or right with the use of the built-in miter gauge.

### NOTICE:

The Model TS-C250P-UST is specifically designed to fit the Carbatec TS-C250P Table saw, although the hole pattern may allow mounting on many table saws, or saws may be modified to allow fitment of the unit. Different mounting hardware may be required (not supplied).

## 2. Product Specifications

### Specifications

Sliding table size .....	228.5 x 1200mm
Extension table size.....	228.5x 600mm
Maximum table travel .....	1540mm
Max. Rip Capacity.....	1240mm
Maximum Crosscutting length .....	1500mm
Miter Gauge Range.....	+60°/-60°
Fence full length.....	1090mm
Fence Scale.....	Imperial / Metric
Net Weight .....	35.2Kg

## ⚠ WARNING

All table saws present severe cutting and amputation hazards. To reduce the risk of these types of personal injuries when using this sliding table attachment, make sure that you read and understand your table saw owner's manual, and that you follow all the safety instructions contained in that manual before beginning any operations.

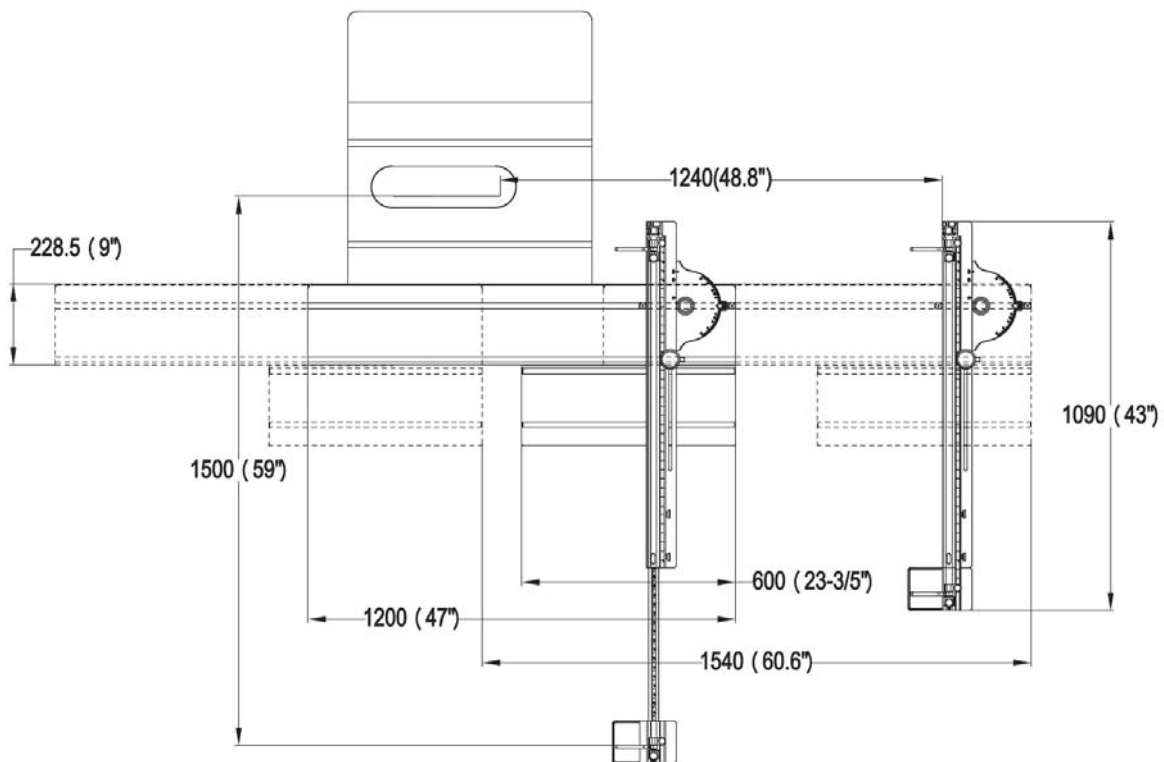

Fig.1

### 3. Inventory

The listing below to inventory the contents of the shipping box.

**Note:**

If you can't find an item on this list, check the mounting locations or examine the packaging materials carefully. Occasionally, previously supplied loose components are pre-installed for shipping purposes.

- A. Sliding Table Assembly..... 1
- B. Support Leg Assembly..... 2
- C. Fence Assembly..... 1
- D. Fence Extension Support Plate..... 1
- E. Extension Table Assembly..... 1
- F. Flip Stop Assembly..... 2
- G. Knurled Pivot Handle Assembly..... 1

**K. Fence Extension Support Plate Mounting Hardware Pack**

- Cap Screws M6-1 x 10..... 4
- Lock Washer 6mm..... 4
- Flat Washer 6mm..... 4

**L. Auxiliary Hardware Pack**

- T-Bolt M8-1.25 x 35..... 2
- Flat Washer 8mm..... 2
- Lock Nut 8mm..... 2

**M. Generic Table Saw Mounting Hardware Pack**

- Cap Screws M8-1.25x 25..... 3
- Lock Washer 8mm..... 3
- Flat Washer 8mm..... 3

**N. Carbatec TS-C250P Table Mounting Hardware Pack**

- Cap Screws M10-1.5x 25..... 3
- Lock Washer 10mm..... 3
- Flat Washer 10mm..... 3

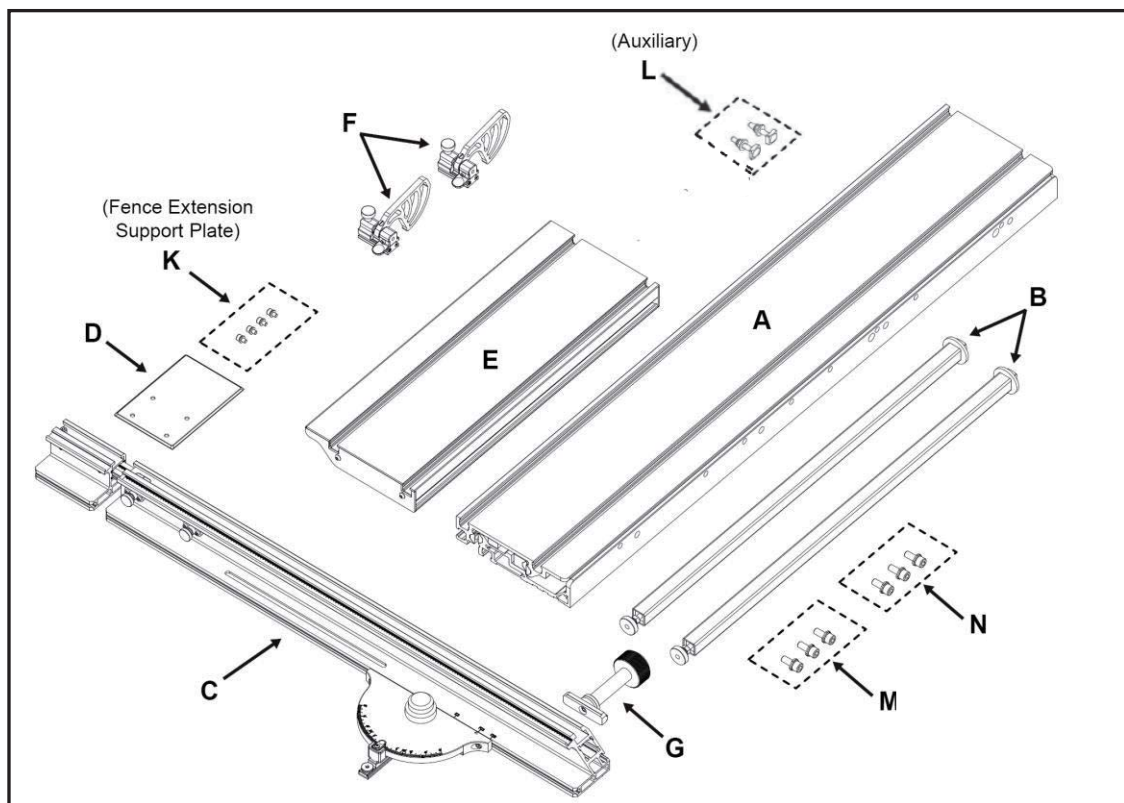

Fig.2

#### 4. Choice of mounting holes

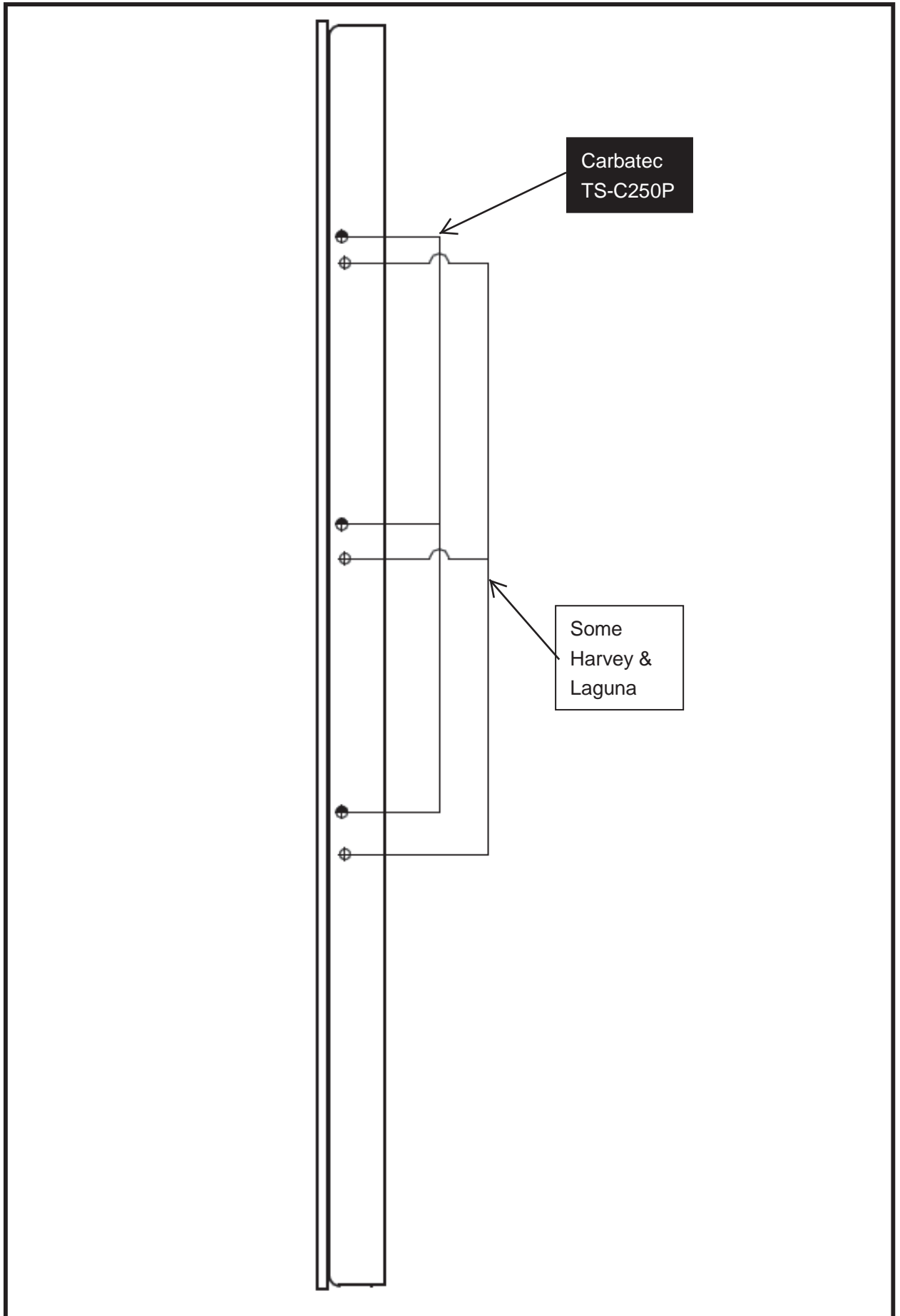

Fig.3

## 5. Assembly

For safe and effective use, the sliding table should be attached to the left side of the saw table and in a way that the sliding table top is even with the table saw top the full length.

1. Disconnect saw from power!
2. the sliding table must be attached to the left side of the saw table in a way that the sliding table top is 2 - 2.5mm higher than the top of the table saw so that workpieces do not drag.  
----if you have a wing attached to the left side of the saw table, remove it.  
----if you do not have a wing attached to the left side of the table or do not have the correct mounting holes for the sliding table, you need to drill and tap three M8-1.25 holes into the saw table to match the sliding table (see **Fig.4**).

**Tip: Use the side of the sliding table to make a template for marking the mounting hole locations on the saw table.**

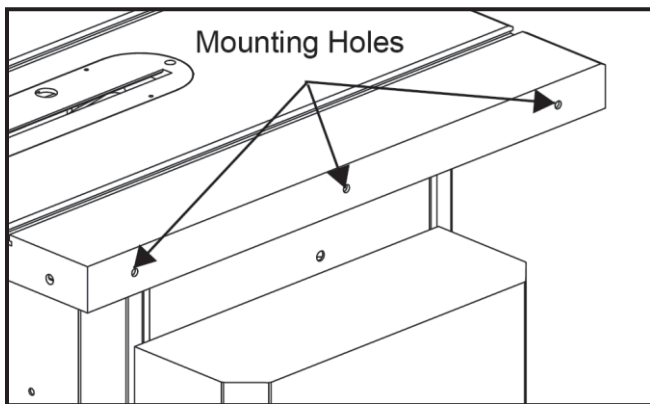

**Fig.4.**

3. Thread the foot pad assemblies into the bottom of the support legs, as shown in **Fig 5**. For now, do not tighten the jam nuts up to the legs so that you can adjust the height of the legs in a later step.
4. Turn the sliding table upside down, slide the support leg t-nuts into the sliding table t-slot (see **Fig.6**), then hand-tighten the legs clockwise to secure them in place.

**Note: For the best support, position the support legs near the edges of the sliding table, as shown in Fig6.**

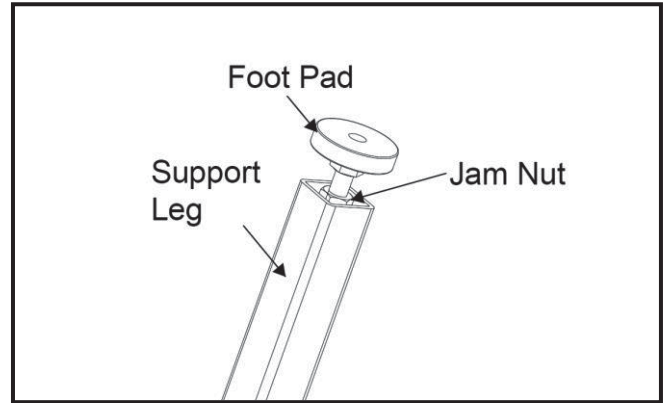

**Fig.5.**

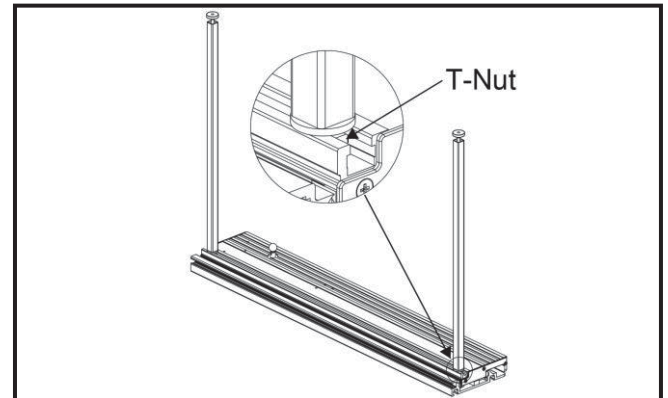

**Fig.6.**

5. With the help of at least one other person to support the weight, turn the sliding table assembly over, then position it against the side of the saw table.

6. Pull out the locking pin that is underneath the sliding table, then slide the top part to one side to expose two of the mounting holes, as shown in **Fig.7**.

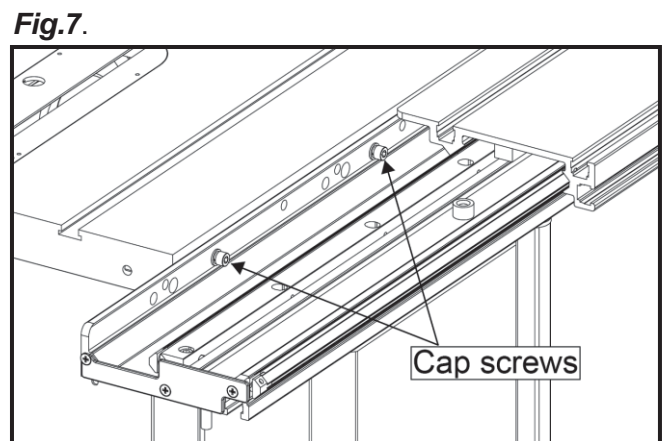

**Fig.7.**

7. Align the mounting holes, then thread two cap screws, lock washers, and flat washers through the sliding table into the mounting holes of the saw table.

8. Slide the table surface in the opposite direction and install the remaining cap screw, lock washer, and flat washer.

9. Adjust the foot pads on the bottom of the legs to fully support the sliding table, then thread the jam nut tightly against the legs to secure the settings.

**Note: Use the precision straightedge to make sure the table tops stay even with one another as you adjust the height of the legs.**

10. If the sliding table does not travel exactly parallel to the saw blade, the workpiece could bind and kickback toward the operator, causing serious personal injury. You **MUST** make sure that the sliding table travels parallel with the saw blade before beginning operation to avoid kickback injuries. You can make fine adjustments by inserting small shims between the main saw table and cast wing, as shown in **Fig.8** to adjust the parallel.

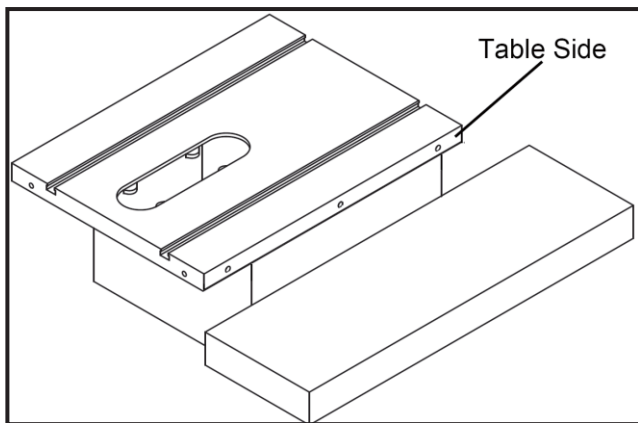

**Fig.8.**

11. Insert the T-nuts of the extension table into the T-slot on the outside edge of the sliding table, then tighten the lock levers to secure the extension table in place, as shown in **Fig. 9**.

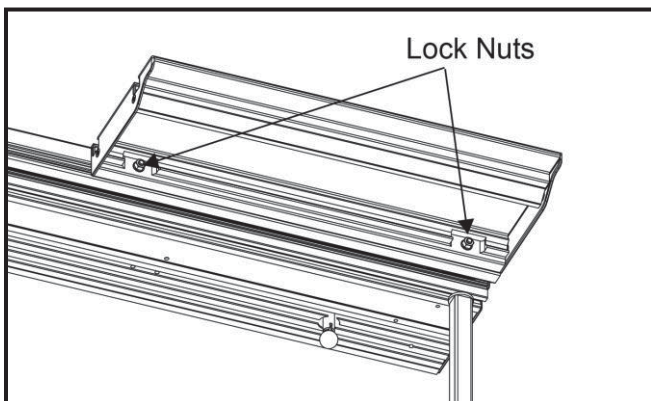

**Fig.9**

**Note: The extension table provides additional workpiece support and should be positioned as needed during operation.**

12. Slide the miter gauge bar into the T-slot on the sliding table top nearest the blade, as shown in **Fig. 10**. For full cutting capacity, the miter gauge bar should be positioned flush with the front edge of the sliding table. Use a 5mm wrench to turn the reverse-thread fasteners at the front and rear of the miter gauge bar **COUNTERCLOCKWISE** to lock the miter gauge bar in place.

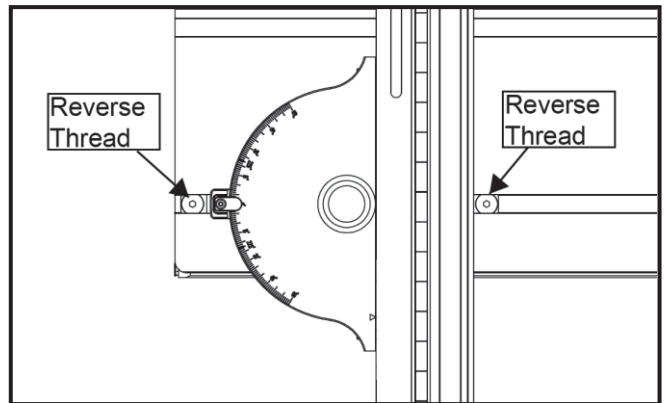

**Fig.10**

13. Use a 5mm allen wrench to slightly loosen the crosscut fence from the miter gauge as shown in **Fig. 11**. **Do not loosen the screws more than 1 ½ full turn.** With the blade guard installed, raise the saw blade to the highest elevation and tilt it to 45 degrees. Pivot the crosscut fence until it is parallel to the front edge of the saw table. Slide the crosscut fence to the right until the right side of the crosscut fence is about 2 inches from the left side of the blade guard. If you want to position the crosscut fence closer to the blade, be careful not to run the crosscut fence into the blade guard or anti-kickback pawls during operation. Retighten the screws.

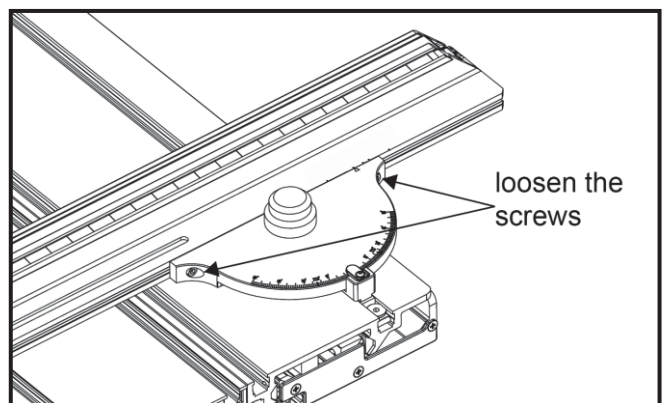

**Fig.11**

**14.** Pivot the crosscut fence counter-clockwise until the left end of the long slot on the crosscut fence is off the saw table. Remove the T-bolt from the Crosscut Fence Lock Knob and insert the threaded shaft of the T-bolt up through the slot on the fence as shown in **Fig. 12**. Pivot the fence clockwise and slide the T-bolt into the T-slot in the left side of the sliding table top. Place the plastic washer on the T-bolt threaded shaft and then screw on the crosscut fence lock knob. Do not tighten the lock knob at this time.

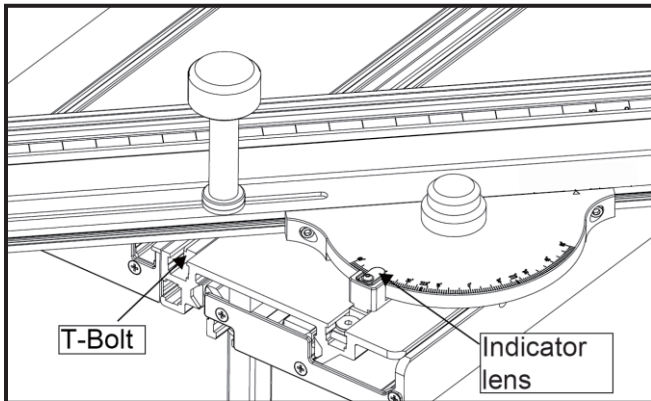
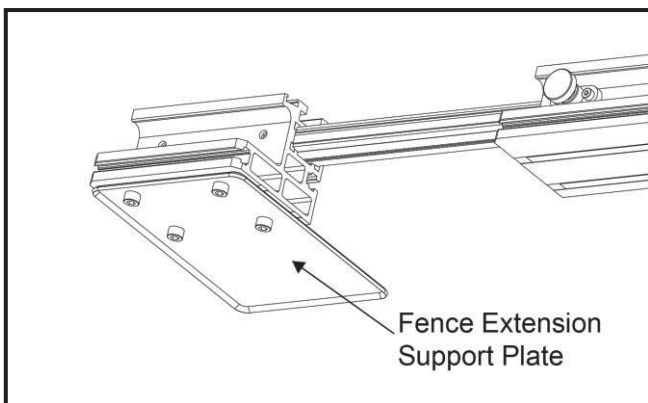

**Fig. 12**

**15.** Use a square to position the fence exactly 90 degrees relative to the saw blade then tighten the crosscut fence lock knob.

**16.** Check the miter gauge angle indicator. If the reading is not 0 degrees, loosen the indicator lens mounting screw and adjust the position of the indicator to read 0 degrees. Retighten the mounting screw, see **Fig. 12**.

**17.** Mount the Fence Extension Support Plate to the bottom of the Fence Extension as shown in **Fig. 13**



**Fig. 13**

**18.** Slide the two flip stops into the T-slot on top of the crosscut fence and then tighten their lock knobs to hold them in place, see **Fig. 14**.

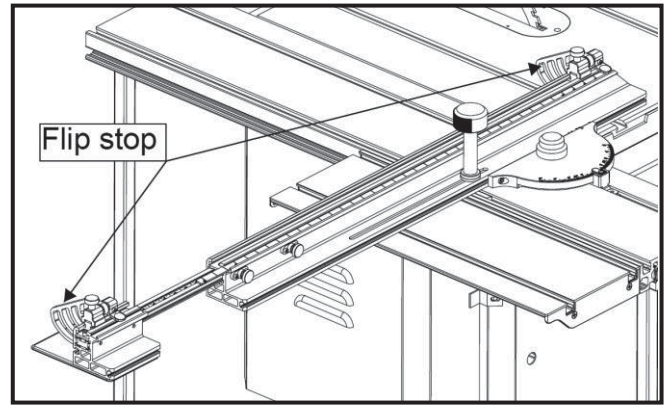

**Fig. 14**

**19.** Using a tape measure to measure the distance between the blade and the flip stop, then adjust the fence ruler, make the indicator in the flip stop indicator lens is equal to the distance you measured.

Congratulations! Your Carbatec TS-C250P-UST Universal Sliding Table Attachment is now installed.

## 6. Operations

**1.** To adjust the crosscut miter angle, loosen the crosscut fence lock knob to allow the crosscut fence to pivot. Using the miter gauge angle indicator, set the fence to the desired miter angle and retighten the lock knob to secure the fence in place.

**2.** To make repetitive cuts, loosen the appropriate flip stop lock knob and slide the flip stop into the desired position. Retighten the lock knob to lock the flip stop in place.

**3.** Unlock the sliding table by pulling out the sliding table lock knob on the underside of the sliding table and rotating it 90 degrees.

**4.** To prevent the sliding table from moving, pull out the sliding table saw lock knob and rotate it 90 degrees. Next, slowly slide the table toward the Home Position until the lock pin engages and the table locks in place. When the sliding table is not in use, lock it in place so that it will not move unexpectedly.

**5.** For longer work pieces (up to 60"), make sure the fence is positioned over the extension table. Next, loosen the crosscut fence extension lock knobs and slide the fence extension to the left as needed to accommodate the longer work piece. Retighten the fence extension lock knobs.

## 7. Parts List

### Sliding table parts

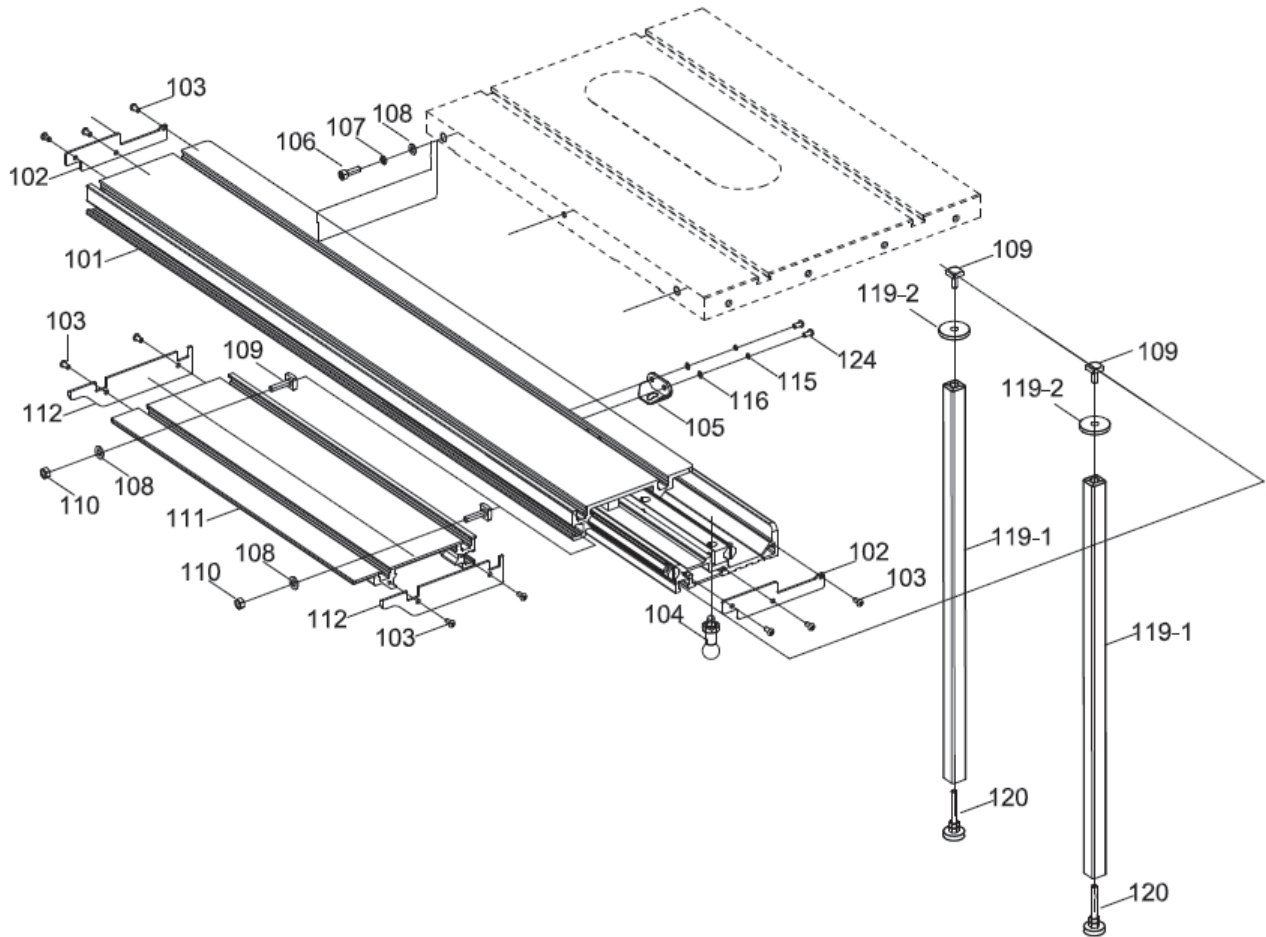

### Sliding table parts list

REF#	DERIPTION	QTY	REF#	DERIPTION	QTY
101	Sliding table	1	110	Lock nut M8	2
102	Sliding table end cover	2	111	Sliding table extension table	1
103	Pan head screw M6-1 X 12	10	112	Extension table end cover	2
104	Sliding table lock knob	1	115	Lock washer 6	2
105	Sliding table limit block	1	116	Flat washer 6	2
106	Cap screw M8-1.25 X25	3	119-1	Support leg	2
107	Lock washer 8	3	119-2	Washer	2
108	Flat washer 8	3	120	Foot	2
109	T bolt	4	124	Pan head screw M6-1 X 10	2



# Sliding table fence parts

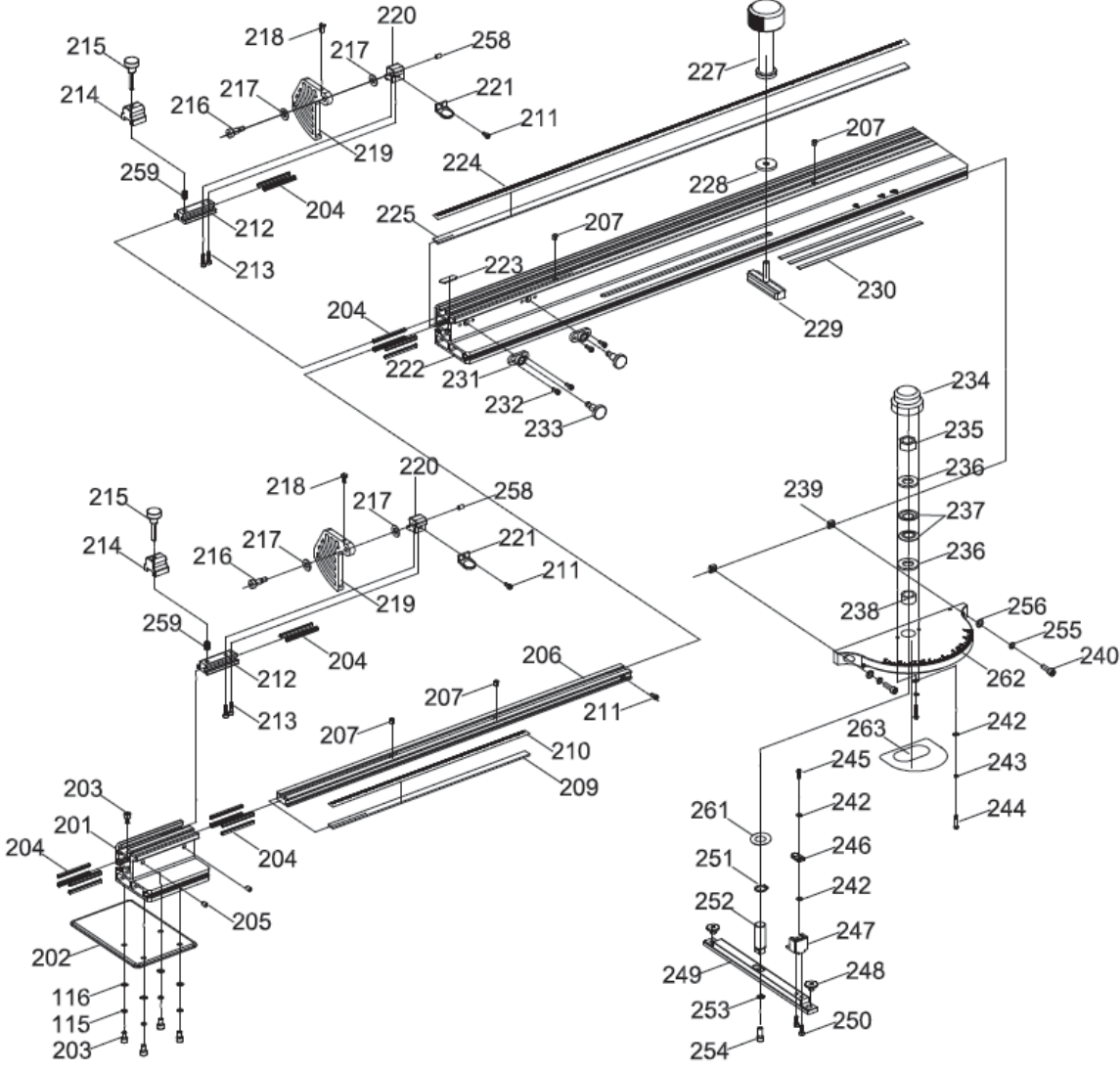

## Sliding table fence parts list

REF#	DERIPTION	QTY	REF#	DERIPTION	QTY
201	Crosscut fence extension	1	232	Cap screw M4-.7 X10	4
202	Support plate	1	233	Screw	2
203	Cap screw M6-1 X10	5	234	Miter gauge cover	1
204	Crosscut fence extension glides	16	235	Lock nut M16	1
205	Set screw M6-1 X10	2	236	Washer	2
206	Crosscut fence extension bar	1	237	Spring washer	2
207	Spring bearings	4	238	Crosscut fence pivot bushing	1
209	Scale body	1	239	Square nut M6	2
210	Scale	1	240	Pan head screw M6-1 X20	2
211	Cap screw M4-.7 X8	3	242	Flat washer 4	4
212	Flip stop bar	2	243	Lock washer 4	2
213	Cap screw M4-.7 X12	4	244	Cap screw M4-.7 X20	2
214	Flip stop lock block	2	245	Pan head screw M4-.7 X12	1
215	Flip stop lock knob	2	246	Angle indicator lens	1
216	Shoulder screw M8-1.25	2	247	Lens mounting block	1
217	Nylon washer	4	248	Flat head screw	2
218	Nylon screw	2	249	Miter gauge bar	1
219	Crosscut fence flip stop	2	250	Cap screw M4-.7 X14	2
220	Stop plate mounting block	2	251	External retaining ring 16	1
221	Flip stop position indicator lens	2	252	Miter gauge pivot shaft	1
222	Crosscut fence	1	253	Lock washer 6	1
223	Indicator lens	1	254	Cap screw M6-1 X16	1
224	Scale	1	255	Lock washer 6	2
225	Crosscut fence ruler body	1	256	Flat washer 6	2
227	Crosscut fence lock knob	1	258	Set screw M6-1 X6	2
228	Washer	1	259	Flip stop lock block spring	2
229	Crosscut fence lock bar	1	261	Washer 16	1
230	Crosscut fence guide pad	3	262	Miter gauge	1
231	Mounting block for extension knob	2	263	Miter gauge glide pad	1

A large, stylized number '2' with a silver-to-gray gradient and a thick black outline. It is positioned above a dark gray rectangular background.

**YEAR**

**WARRANTY**

# WARRANTY

## 1. WARRANTY

- (a) We warrant that this **carbatec** product will be free from defects caused by faulty workmanship or faulty materials for a period of 2 years from the date of sale.
- (b) This warranty is in addition to other rights and remedies you may have under a law in relation to the goods.
- (c) This warranty does not apply in any of the following cases:
  - (i) defects arising from:
    - (1) fair wear and tear;
    - (2) corrosive atmosphere;
    - (3) damage or injury caused by deliberate act, lack of care or failure to comply with the recommended care and maintenance for the goods;
    - (4) improper use of the goods;
    - (5) alterations or repairs (not made by us) to the goods;
  - (ii) defects arising from an event outside of our control such as fire, flood, earthquake or other natural calamity, motor vehicle or other accident, strike, civil unrest, terrorism or war;
  - (iii) to accessory items such as after-market jigs, accessories or other items which are not sold or serviced by us and which are not sold with or were not included with the main unit purchased; or
  - (iv) to wearable parts such as drive belts/shafts, bearings, bandsaw tyres, motor brushes, blades or abrasive belts/discs or other cutting or machining implements.
  - (v) damage caused to any electrical component, where connected to a power supply outside the country for which it was designed (namely Australia or New Zealand).
- (d) If this warranty applies and you have complied with the procedure below for making a claim, we will, at our election, either repair the goods (or those parts of the goods recognised as defective) or will provide a replacement within a reasonable time at our expense.
- (e) If this warranty applies, the procedure for making a claim is:
  - (i) you must contact us by email;
  - (ii) you must include in the email the following information:
    - (1) a copy of the order or receipt for the goods;
    - (2) the serial or batch number printed on the machinery manufacturing plate; and
    - (3) a detailed description of the fault and how and when it arose; and
  - (iii) if the fault is a type covered by this warranty, we will then make arrangements with you for the return of the goods to us (for repair or replacement) at our cost using our transport providers or we may decide to attend at your premises to repair or replace the goods.
- (f) Our liability (and that of our resellers) under this warranty is wholly limited to repair or replacement of the goods (or those parts of the goods recognised as defective) in accordance with the procedure above and you have no right to other compensation, costs or damages under this warranty. But this does not mean that you may not have other rights under a law in relation to the goods.
- (g) If following our inspection of goods returned by you under this warranty it is found that this warranty does not apply and you are not otherwise entitled to repair or replacement by us, you must, if requested by us, reimburse our costs including parts, labour and freight.
- (h) This warranty is not transferable and only the person who purchased the goods may make a claim.
- (i) Where the goods have been exported outside Australia or New Zealand, the Company may not require the Purchaser to return any allegedly faulty or defective Product for evaluation. However, the Company has the right to request the return for evaluation at purchasers cost.

## 2. STATUTORY NOTICE

Our goods come with guarantees that cannot be excluded under the Australian Consumer Law. You are entitled to a replacement or refund for a major failure and for compensation for any other reasonably foreseeable loss or damage. You are also entitled to have the goods repaired or replaced if the goods fail to be of acceptable quality and the failure does not amount to a major failure.

## 3. CONTACT DETAILS

Carbatec Pty Ltd ABN 84 010 706 242

info@carbatec.com.au | Phone 1800 658 111 | www.carbatec.com.au

128 Ingleston Road, Wakerley, QLD Australia 4154

Carbatec Pty Ltd  
ABN 84 010 706 242

[info@carbatec.com.au](mailto:info@carbatec.com.au)

Phone: 1800 658 111  
128 Ingleston Road, Wakerley  
Queensland Australia 4154

[www.carbatec.com.au](http://www.carbatec.com.au)

**carbatec**